

Physical Dimension

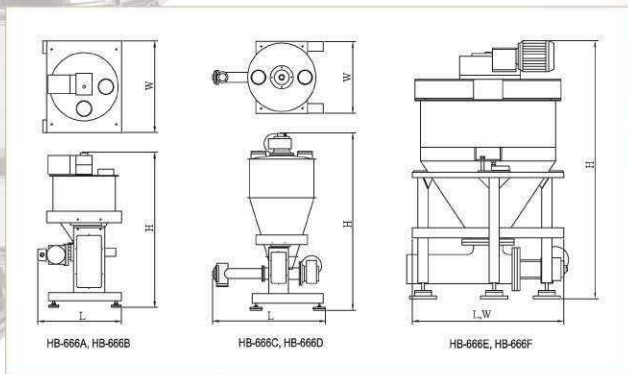

All these advantages combined in the HB-8268

Series measuring system!

- Extremely user friendly operator interface, including self-prompting instructions and messages.
- Sealed membrane full-function keyboard.
- Multi-function display, including a 128 x 64 dots LCD display, full alpha-numeric read-out messages and instructions.
- Total password security for protection of calibration constants and rerate (capacity re-program ming) parameters.
- Electrically isolated inputs and outputs. Additional inputs and outputs available with expansion modules.
- Isolated A/I, A/O ; A/I : 1P , A/O : 4P
- Max. 8 dry contact input or NPN open collector transistor input. (option up to 32 D/I)
- Max. 8 NPN open collector transistor output
- Panel mount and Wall mount enclosures available.
- User programmable Zero Speed Switch for belt weighers and belt feeders.
- User programmable rerate functions.
(All variables for reconfiguring scale or feeder capacity or operating parameters).
- Programmable for Mater/Slave, Ratio, or Blending Operations.
- Automatic belt deviation monitoring. / Automatic belt slip monitoring.
- User selectable English or Metric units of measurement.
- Remote operation keyboard for systems.(Option)
- Printer interface is available.(Option)
- Chart recorder interface is available.(Option)
- Excellent immunity to RFI and EMI.



● HB-8268

HB
HOLBRIGHT

HB-666 SERIES

LOSS IN WEIGHT FEEDING SYSTEM



HOLBRIGHT WEIGHING SYSTEMS CO., LTD.
4F, NO. 31, LANE 21 MIN CHUAN EAST RD., SEC. 6 NEI HU,
TAIPEI, TAIWAN.
TEL: 886-2-8792-0786 FAX: 886-2-8701-2380
<http://www.holbright.com.tw>
E-mail: sales@holbright.com.tw